

ECARTONI**E**

PROFESSIONAL CAMERA SUPPORT

FOCUS 12 ✓

USER'S MANUAL & Maintenance





CERTIFICATO N. 19714/09/S CERTIFICATE No.

SI CERTIFICA CHE IL SISTEMA DI GESTIONE PER LA QUALITÀ DI
IT IS HEREBY CERTIFIED THAT THE QUALITY MANAGEMENT SYSTEM OF

CARTONI S.P.A.

VIA DI PORTONACCIO, 33/B 00159 ROMA (RM) ITALIA

NELLE SEGUENTI UNITÀ OPERATIVE / IN THE FOLLOWING OPERATIONAL UNITS

VIA DI PORTONACCIO, 33/B 00159 ROMA (RM) ITALIA

È CONFORME ALLA NORMA / IS IN COMPLIANCE WITH THE STANDARD
ISO 9001:2015

PER I SEGUENTI CAMPI DI ATTIVITÀ / FOR THE FOLLOWING FIELD(S) OF ACTIVITIES

IAF-17
IAF-29

PROGETTAZIONE, FABBRICAZIONE ED ASSISTENZA POST-VENDITA DI PRODOTTI PER LA CINEMATOGRAFIA E LA TELEVISIONE PROFESSIONALE. COMMERCIALIZZAZIONE DI PRODOTTI ED ACCESSORI IN CONCESSIONE PER LA CINEMATOGRAFIA E LA TELEVISIONE PROFESSIONALE

DESIGN, MANUFACTURE AND POST-SALE ASSISTANCE OF PROFESSIONAL BROADCAST AND FILM EQUIPMENT. MARKETING OF PROFESSIONAL BROADCAST AND FILM ACCESSORIES AND PRODUCTS AS LOCAL AGENCY REPRESENTATIVE

La validità del presente certificato è subordinata a sorveglianza periodica annuale / semestrale ed al riesame completo del sistema di gestione con periodicità biennale

The validity of this certificate is dependent on an annual / six monthly audit and on a complete review, every three years, of the management system

L'uso e la validità del presente certificato sono soggetti al rispetto del documento RINA: Regolamento per la Certificazione di Sistemi di Gestione per la Qualità

The use and validity of this certificate are subject to compliance with the RINA document: Rules for the certification of Quality Management Systems

Prima emissione First Issue	12.06.2009	Data decisione di rinnovo Renewal decision date	24.05.2018
Data scadenza Expiry Date	02.06.2021	Data revisione Revision date	24.05.2018

Amilcare Rini
Rome Management System
Certification, Head

RINA Services S.p.A.
Via Corsica 12 - 16128 Genova Italy



SGQ N° 002 A

Members degli Accordi di Mutua
Riconoscimento DA, IAF e ILAC
Signatories of DA, IAF and ILAC
Mutual Recognition Agreements



www.cisq.com

CISQ è la Federazione Italiana di Organismi di
Certificazione dei sistemi di gestione aziendale
CISQ is the Italian Federation of
management system Certification Bodies

1.	SAFETY & SET-UP INTRODUCTION	5
2.	OPERATING ELEMENTS	6
3.	PROCEDURES	8
4.	SPECIFICATIONS	9
5.	MAINTENANCE	10
6.	WARRANTY	10
7.	ACCESSORIES & PRODUCT LINE	11



1. SAFETY & SET-UP INTRODUCTION

The **FOCUS 12** Fluid Head is the ideal support for the latest smaller, lighter high-performance Cameras weighing from 0 to 12 kg (0 to 26.4 lbs).

Extremely compact and lightweight, the innovative **FOCUS 12** features a continuously variable fluid damping system on both pan and tilt movements and an unrivaled patented variable counterbalance which brings its range of use to cover all existing ENG and lighter high-performance Cameras.

The **FOCUS 12** Head comes equipped with a sliding quick release European Camera plate plate, illuminated spirit level and telescopic pan bar. Its tilting range is +/- 90° has a perfect response throughout the entire tilt range. This head interfaces with all 100 mm bowl base Tripods and supports.

The extreme ruggedness and versatility together with a superior quality/price ratio makes the **FOCUS 12** the best possible support for independent content creators, news Operators and Videographers.

- ✓ Before using the product read this user manual.
- ✓ Before installing the Fluid Head on the Tripod check the Tripod stability.
- ✓ Verify that the Camera payload (including lens and all accessories) is lower than the maximum capacity of the Fluid Head.
- ✓ Before setting up the Camera make sure that the Fluid Head is in good conditions and bares no evident damages.

2. OPERATING ELEMENTS

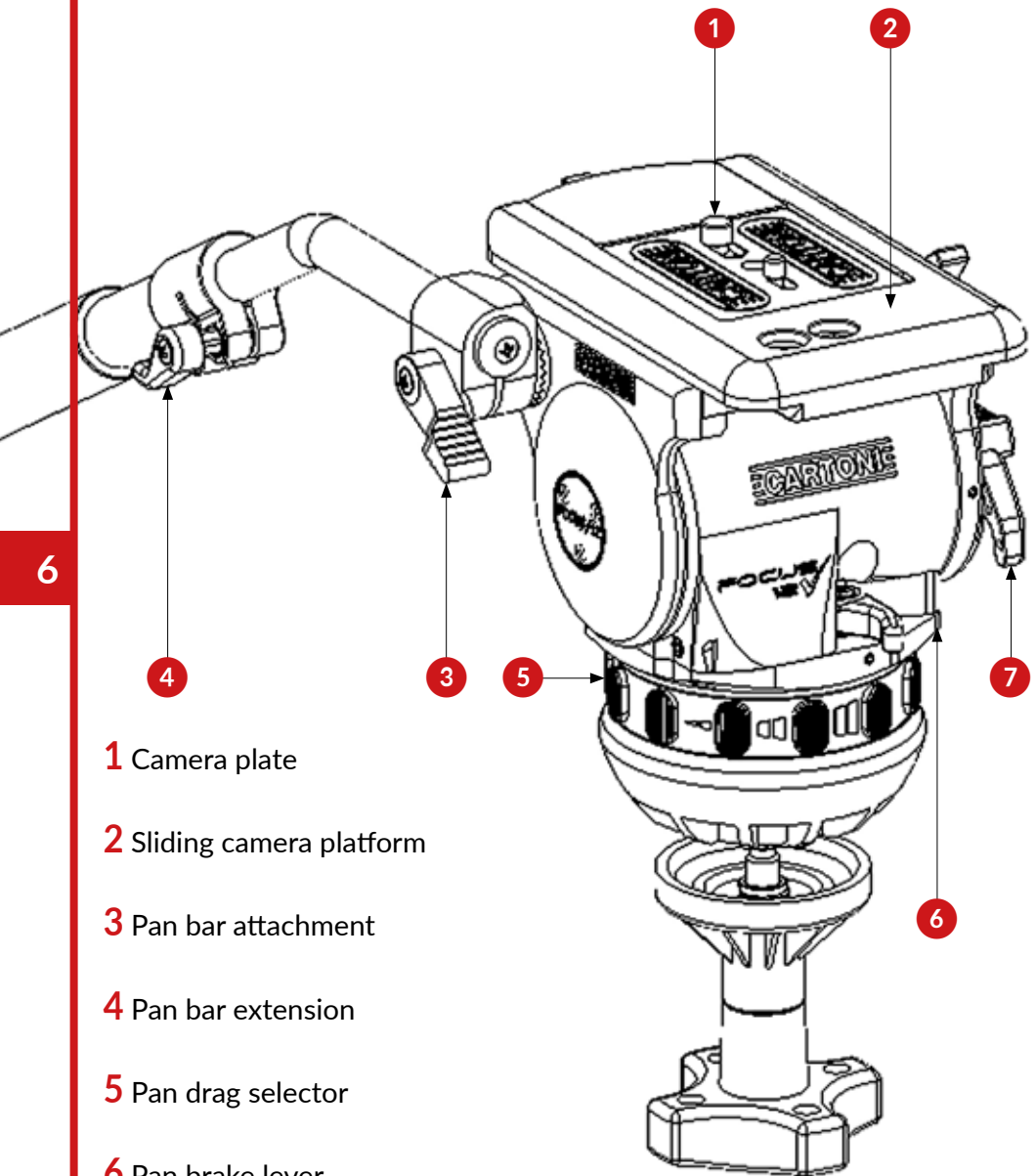

1 Camera plate

2 Sliding camera platform

3 Pan bar attachment

4 Pan bar extension

5 Pan drag selector

6 Pan brake lever

7 Tilt brake lever

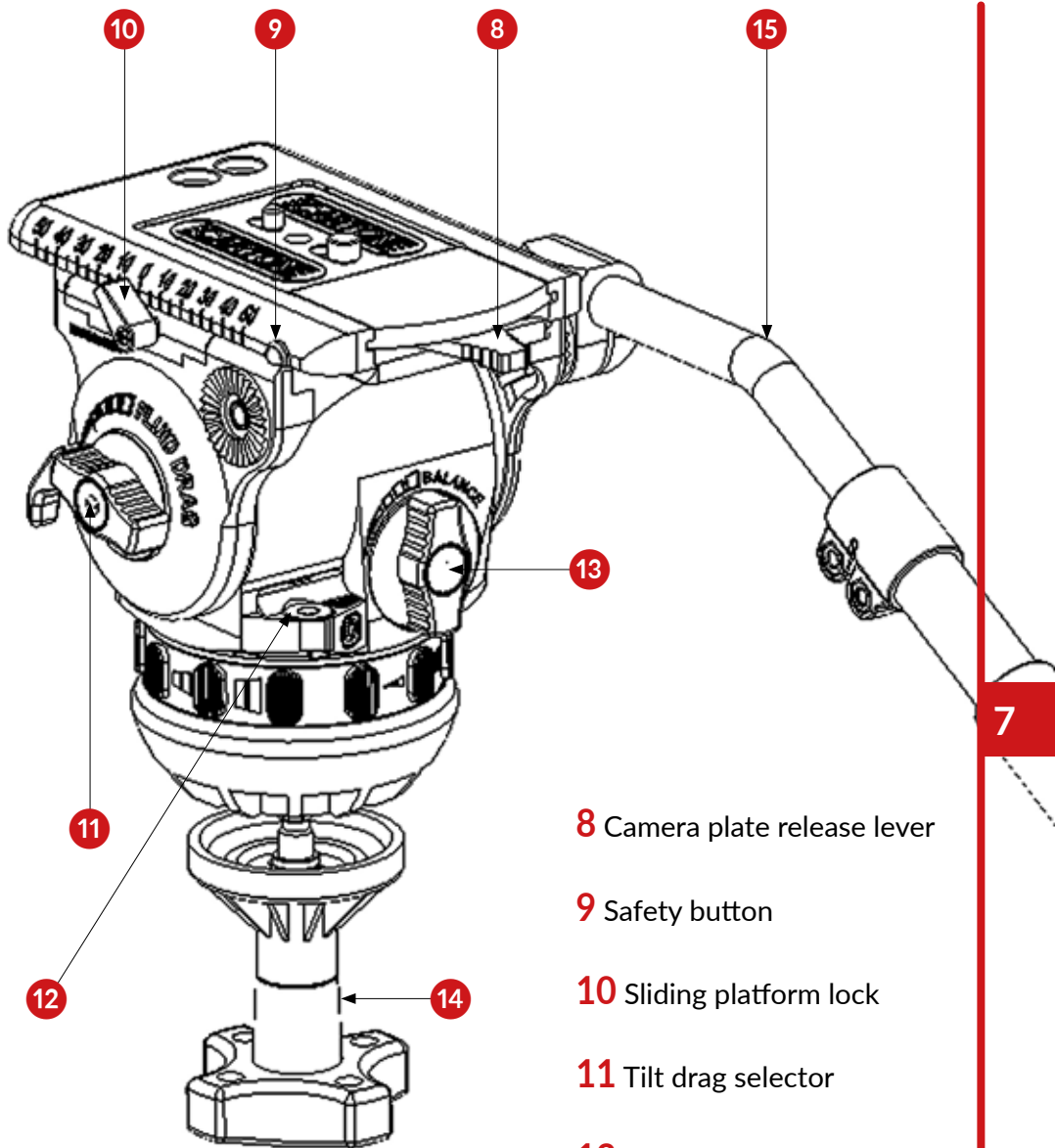

8 Camera plate release lever

9 Safety button

10 Sliding platform lock

11 Tilt drag selector

12 Illuminated spirit level

13 Counterbalance selector

14 Tie down knob

15 Pan bar

3. PROCEDURES

- ✓ Place the **FOCUS 12** on your Tripod by loosening the tie-down knob (14) under the Fluid Head and level using the level bubble (12). In low light conditions, press button (12) for light.
- ✓ Connect the Pan bar (15) to the Fluid Head tightening the lever (3) on the Pan bar attachment and select your desired operating angle. The telescopic Pan bar length can be adjusted via lever (4).
- ✓ Lock both Pan and Tilt brakes (6 & 7), turn both Tilt drag selector (11) and counterbalance knob (13) to the minimum.
- ✓ Open the Camera plate lock lever (8) completely to release the Camera plate (1).
- ✓ Remove the Camera plate (1) from the sliding Camera platform (2) by squeezing simultaneously Camera plate lever (8) and the safety button (9). Attach the Camera plate (1) to the bottom of the Camera and tighten the clamping screw to secure the Camera. Try to center the Camera plate on the Camera, keeping the center of gravity position in mind.
- ✓ Lock the sliding platform lever (10), click the Camera into the quick release sliding platform (2), the plate will lock into place.
- ✓ Hold the Camera in horizontal position with the Pan bar (15) and release the Tilt brake lever (7). Release the sliding platform lever (10) and find the correct center of gravity position, by sliding the Camera platform (2) back and forth until you have achieved the correct balance. Lock the sliding platform lock (10).

- ✓ Set the counterbalance system by turning the balance knob clockwise (13) to appropriate tension. The Camera has to stay at any tilt angle. Eventually fine-tune by adjusting the sliding plate.

Unlock the Pan brake lever (6) and set the Fluid drag control by adjusting selectors (5 & 11).

- ✓ When spirit bubble light fails it is time to replace the batteries (12). Pull out the battery tray.

4. SPECIFICATIONS

Minimum payload	0 Kg	0 lbs
Maximum payload	12 Kg	26.4 lbs
Weight	2,5 Kg	5.5 lbs
Bowl diameter	100 mm	
Fluid control	Continuous	
Counterbalance	Continuous	
Pan range	360°	
Tilt range	+/- 90°	
Temperature range	-40 / +60 °C	-40 / +140 °F

5. MAINTENANCE

With indoor use - when needed - just clean the **FOCUS 12** and Tripod with a soft cloth. Dirt accumulated during storage may be removed using a brush or Air spray.

CARTONI products main mechanisms are sealed as they are also built for professional outdoor use.

However, use under rough conditions will require special care. Salt water is very corrosive and can cause extreme damages. In attempt to avoid further damage the Fluid Head should be washed off with fresh water at the earliest opportunity and dried before storage.

Sand and dirt are abrasive and should be removed using a semi-stiff brush or Air spray.

Disconnect the spirit level battery during long term storage.

6. WARRANTY

All **CARTONI** Fluid Heads & Pedestals have a free of charge three (3) year warranty. Register your product at www.cartoni.com within 30 days from date of first purchase/invoice to receive further two (2) year warranty for the unsurpassed free five (5) year warranty.

Tripods, spreaders, dollies and all accessories are guaranteed one (1) year from the date of first purchase/invoice.

CARTONI warrant that the product supplied will - under proper use - be free from defects in workmanship and materials and agrees that it will, at its option, either repair or replace any defective part within duration of warranty from date of first purchase with no labour charge.

This warranty does not apply to any **CARTONI** product that has been damaged in shipping or handling, abused, misused, operated contrary to instructions for use, neglected, normal wear or tear, modified or changed in design or construction or serviced by unauthorized parties.

Repairs or misuse by any unauthorized parties will void this warranty.

Warranty claims must be submitted – in writing - to the factory for verification or to an authorized distributor/dealer designated by **CARTONI**.

It is the end user's responsibility when ordering to ensure that the products ordered conform to his requirements.

All freight of product to **CARTONI** must be prepaid. All implied warranties are limited to the time period set forth herein & subject to change without notice.

No liability can be accepted for any variation.

7. ACCESSORIES & PRODUCT LINE

For the complete Accessories list & Product line please visit **CARTONI**'s official website **www.cartoni.com**.

Every product has an updated list of compatible items sorted by groups, with descriptions and technical data.



CARTONI
PROFESSIONAL CAMERA SUPPORT

CARTONI S.p.A
Via di Portonaccio, 33/B - 00159 Rome (Italy)
Phone +39 06 4382002
Fax +39 06 43588293
Email: cartoni@cartoni.com
www.cartoni.com