

New Product Introduction

Sachtler
Video 18 S2

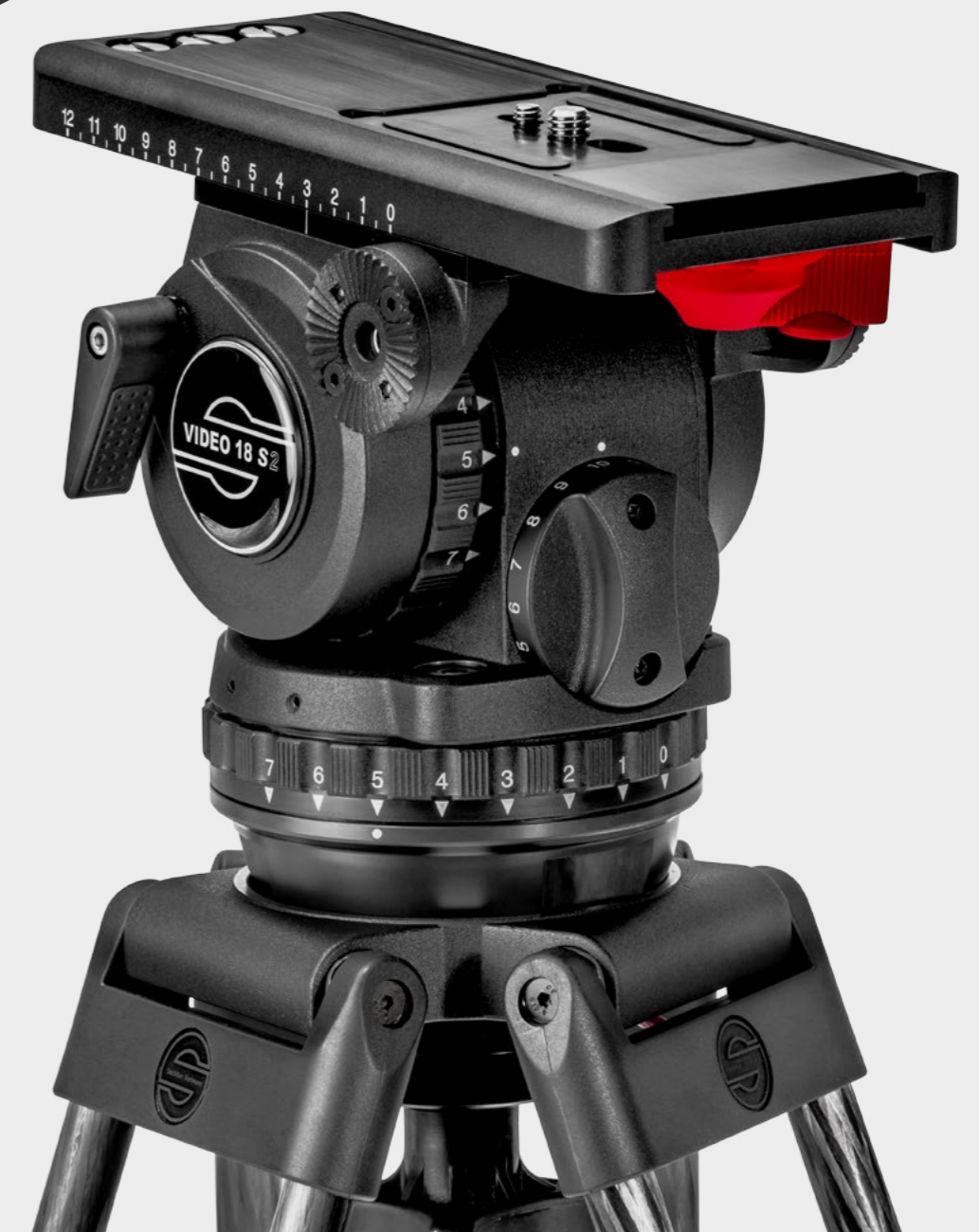

You are ready to sell.



Understand commercial goals, target customers, product advantages and pricing.

Sales Guide

Find the systems that go with the Video 18 S2.

System Overview

See how we inform the world through PR.

Public Relations

Find communication templates to promote the product.

Collateral

See how we inform the world.

Advertisements

Download product images for your website or presentations.

Images

See how our users work with our products.

Testimonials

Download video for your website or presentations.

Video

Visit the product website.

Website

See what happens when.

Key Milestones

Contact

Video 18 S2

Greater Payload - Smooth Operation - Same great price



SALES GUIDE

Sales Pitch

Just when you thought we couldn't get any better, we present the Sachtler Video 18 S2

- ▶ The only head in its class to offer smooth head operation at -40°C to +60°C.
- ▶ Ability to support a full size ENG rig with up to 20 kg / 44.1 lbs.
- ▶ Super smooth drag performance.
- ▶ Super performance for an even greater payload at the same great price.

Key Values

- ▶ Very smooth, jerk free drag feeling.
- ▶ Drag mechanism provides the same value of drag output for both vertical and horizontal movements.
- ▶ Stepped mechanism ensures easily repeatable drag set-up.
- ▶ Speedbalance counterbalance mechanism precise and fast to set-up
- ▶ Very wide payload range.
- ▶ Proven robustness and reliability, rugged fluid head.

- ▶ Works reliably over a wide temperature range.
- ▶ Camera platform incorporates long sliding range for ease of balance.
- ▶ Touch & Go camera plate attachment which is very fast.
- ▶ Ergonomics which suit the work environment (large levers, all accessible from one side, intuitive operation).
- ▶ Long lifetime = good investment.
- ▶ Very good brake performance.
- ▶ Park positions for spare camera screws.
- ▶ [Systems include Speedlevel clamp.](#)

Commercial Goal

- ▶ Leverage launch to position Sachtler as brand of choice in electronic news gathering.

Customer

- ▶ ENG News
- ▶ Documentary
- ▶ Rental
- ▶ Broadcast corporations as well as freelance cameramen

Technical Information

Sachtler Video 18 S2

- **Weight:** 4,1 kg / 9 lbs
- **Payload Range:** 2 - 20 kg / 4 - 44.1 lbs
- **Balance plate / Sliding range:** 120 mm / 4.7 in
- **Counterbalance steps:** 16 + Boost Button
- **Drag:** 7 horizontal and vertical drag settings + 0
- **Tilt range:** +90° / -70°
- **Temperature range:** -40° - +60°C (-40 - +140° F)
- **Camera fitting:** Touch & Go plate 16
- **Tripod fitting:** 100 mm bowl
- **Pan bar:** Includes 1 telescopic pan bar (pan bar plus right)
- **Level bubble:** Illuminated level bubble Type CR2032

Optional Accessories:

- Pan bar Plus left (3271)
- C.O.G. plate (1063)
- Adapter FB/100 (3903)
- Adapter Ped CI/Plus (3941)
- FB Converter (3913)
- Adapter 100/150 (3901)
- Adapter viewfinder extension 18/20 (3981)
- Adapter (3985)
- Speedlevel Clamp (S2044-0001)

WHAT'S NEW

- ▶ 4 kg / 8.8 lbs more payload than Video 18 S1.

COMBINE THIS PRODUCT WITH THE NEW
LITEPANELS BRICK ON CAMERA LIGHT

ORDER CODE	LIST PRICE				AVAILABILITY	DEMO PRODUCT
1811 - SACTLER VIDEO 18 S2	\$5,500	£3,500	€4,500	¥750.000	18. APRIL	50% DISCOUNT
1862S2 - SYSTEM 18 S2 ENG 2 CF	\$8,200	£5,200	€6,600	¥1.069.000	18. APRIL	50% DISCOUNT
1863S2 - SYSTEM 18 S2 ENG 2 MCF	\$8,600	£5,400	€6,900	¥1.130.000	18. APRIL	50% DISCOUNT
1865S2 - SYSTEM 18 S2 SL MCF	\$8,900	£5,600	€7,100	¥1.195.000	18. APRIL	50% DISCOUNT

Sachtler Video 18 S2 Head Specifications

Measurement in mm

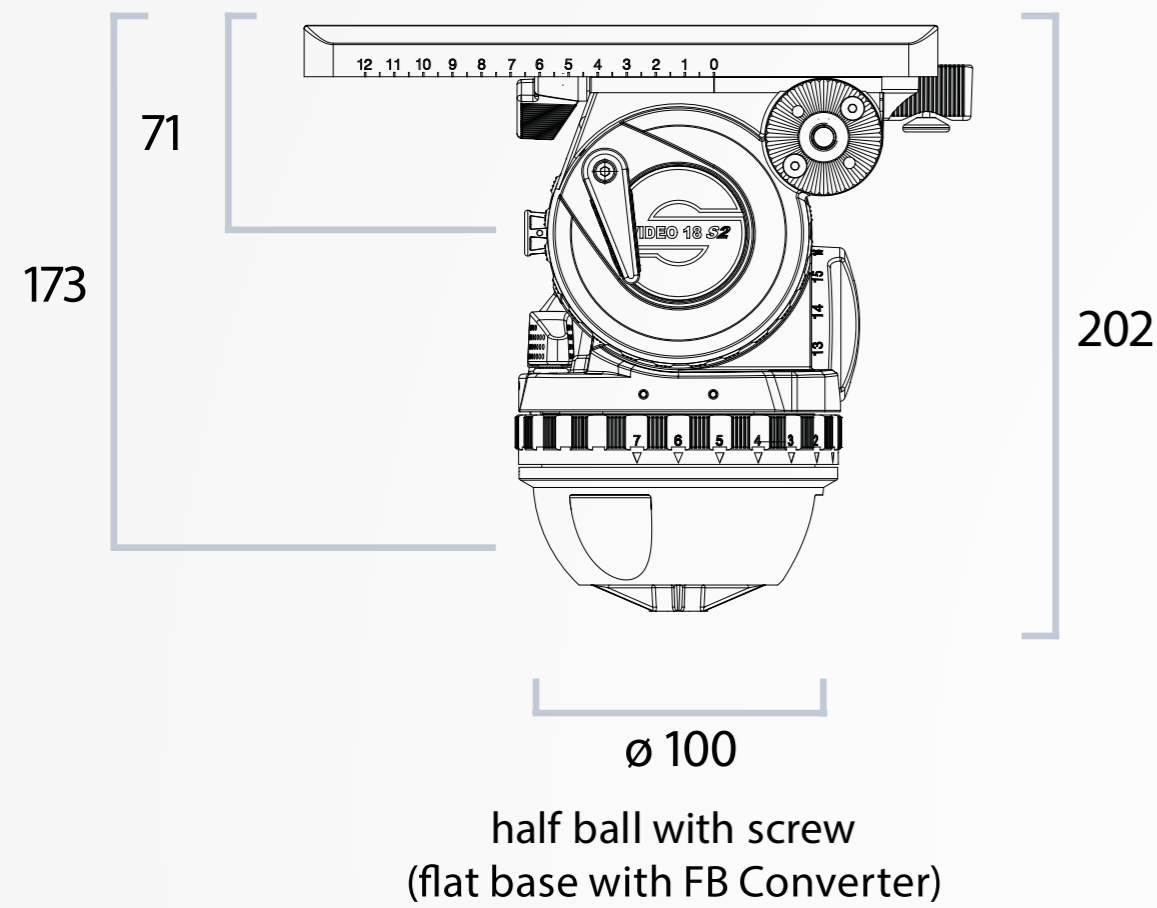

Payload

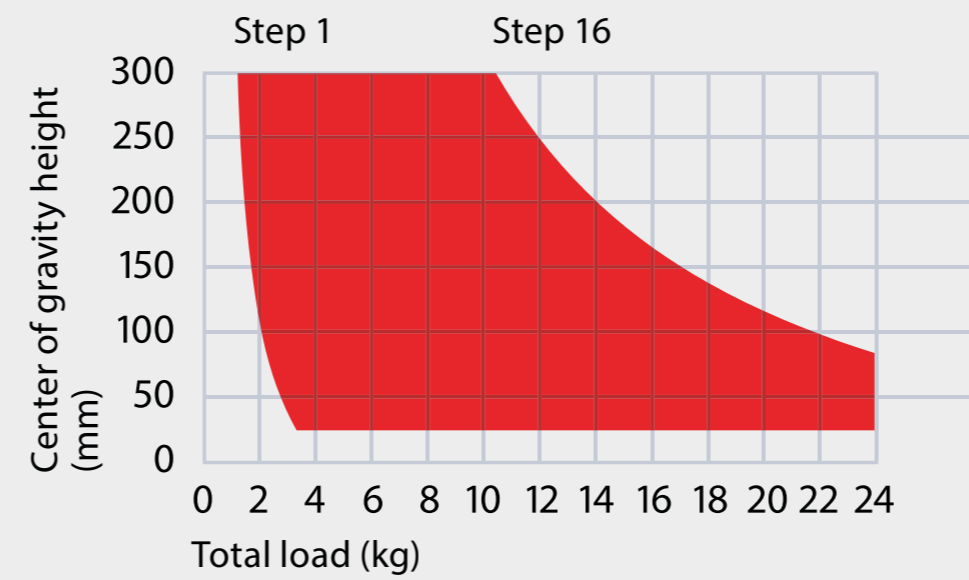

Drag

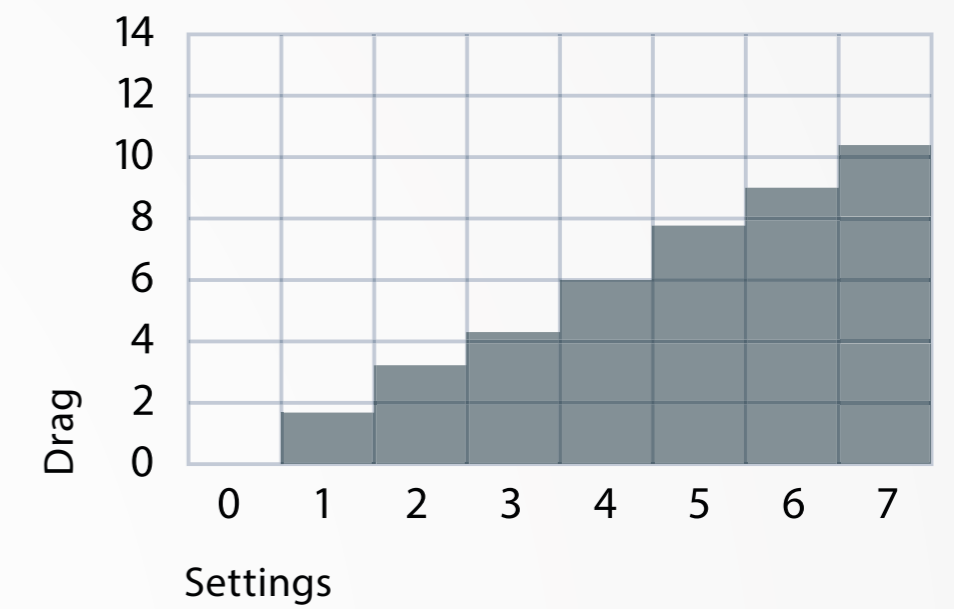

Sachtler Video 18 S2 System Overview



System	System 18 S2 ENG 2 CF	System 18 S2 ENG 2 MCF	System 18 S2 SL MCF
Code	1862S2	1863S2	1865S2
Payload	2 - 20 kg / 4 - 44.1 lbs	2 - 20 kg / 4 - 44.1 lbs	2 - 20 kg / 4 - 44.1 lbs
Weight	7.6 kg / 16.8 lbs	8.1 kg / 17.9 lbs	8.6 kg / 18.9 lbs
Height (Min-Max)	63 - 172 cm 24.8 - 67.7 in	67 - 168 cm 26.4 - 66.1 in	67 - 168 cm 26.4 - 66.1 in
Transport length	89 cm / 35 in	89 cm / 35 in	89 cm / 35 in
In the Box	Video 18 S2 fluid head (1811) tripod ENG 2 CF (5386) ground spreader SP 100 (7002) padded bag ENG 2 (9104) Speedlevel Clamp S2044-0001	Video 18 S2 fluid head (1811) tripod ENG 2 CF (5386) mid-level spreader 100/150 (7007) rubber feet 100/150 (7004) padded bag ENG 2 (9104) Speedlevel Clamp (S2044-0001)	Video 18 S2 fluid head (1811) tripod Speed Lock CF (5586) mid-level spreader 100/150 (7007) rubber feet 100/150 (7004) padded bag ENG 2 (9104) Speedlevel Clamp (S2044-0001)
Price	\$8.200 £5.200 €6.600 ¥1.069.000	\$8.600 £5.400 €6.900 ¥1.130.000	\$8.900 £5.600 €7.100 ¥1.195.000

Sachtler Video 18 S2 Family Overview



Fluid Head	Video 15 SB	Video 18 S2	Cine 7+7
	Lower weight/price alternative		Sideload Alternative
Payload	1-16 kg / 2 - 35 lbs	2 - 20 kg / 4 - 44.1 lbs	2 - 20 kg / 4 - 44.1 lbs
Weight	3.2 kg / 7.1 lbs	4.1 kg / 9 lbs	4.1 kg / 9 lbs
Counterbalance	12 counterbalance steps	16 counterbalance steps +Boost Button	16 counterbalance steps +Boost Button
Drag	7 horizontal and vertical drag settings +0	7 horizontal and vertical drag settings + 0	7 horizontal and vertical drag settings + 0
Temperature Range	-40° to +60° C (-40° to 140° F)	-40° to +60° C (-40 to 140° F)	-40° to +60° C (-40° to 140° F)
Tilt Range	+90° to -75°	+90° to -70°	+90° to -80°
Camera Fitting	Touch & Go 16	Touch & Go 16	Sideload M
Price	\$4.700 £2.850 €3.700 ¥535.000	\$5.500 £3.500 €4.500 ¥750.000	\$7.100 £4.500 €5.800 ¥900.000

Sachtler Video 18 S2 Press Release

Sachtler Video 18 S2

SACHTLER'S BESTSELLING VIDEO 18 FLUID HEAD UNDERGOES A MAJOR UPDATE IN TIME FOR NAB 2016

Eching, Germany (April 15, 2016) – Sachtler, a premier provider of camera supports, accessories, and bags and a Vitec Videocom brand, is upgrading their bestselling fluid head to introduce the Video 18 S2. Thanks to this new model, the Video 18 S2, users will now be able to handle a greater load bearing capacity of up to 20 kg, which is 4 kg more payload than the Video 18 S1. With this improvement, the Video 18 S2 is now the only head in its class that can operate at -40 to +60 degrees centigrade without any impact on its smooth operation.

„The more you can carry on the tripod, the easier it is to function with both the heaviest and the lightest payload. With certain competitors, their tripods can carry a heavier payload, but then the minute you try to adjust your parameters to accommodate a lighter one it feels incredibly stiff and cocky,” commented cinematographer Clinton Harn.

As a cinematographer, filmmaker, producer, and audio recording engineer, Clinton Harn has not only shot for two-time Academy Award winner and director Malcolm Clark, but has also worked as an AC and camera operator for Rodney Charters, ASC, who's known for shows like 24, Dallas, and Shameless.

“This new head just has more control, so while it can accommodate a heavier payload of 20 kg, you can still go down to the minimum drag setting of 2 kg and put a small DSLR camera on there with no issues. And that's the big difference between Sachtler and a lot of other competitors,” said Harn.

For decades, the sturdy Video 18 fluid head has remained a must-have in camera kits of successful EFP and EB cameramen worldwide. During his three-month stay on a remote island, National Geographic filmmaker and photographer Bertie Gregory commented on the Video 18 S1, “I've taken it in little boats and big boats, put it in salt water and sand to get water level shots, had it in rivers and carried it 30 kilometers a day for ten days. In the past, I've had tripods where you take it on a windy beach, the whole thing just fills up with sand, and then I have to take it apart to clean it. I don't know what Sachtler's done with their gear, but whatever it is, it's genius because I never have to worry about doing that.”

And while the Video 18 S2 is optimized in every product detail, this tripod system still maintains classic Sachtler features like temperature resistance, the Touch & Go plate, the parking position for spare camera screws, the illuminated spirit level, and the infamous SpeedLevel Clamp that replaces the traditional tie down on a tripod with a simple push and release mechanism.

“The Video 18 S2 is the best of both worlds for news and documentary film crews. Every microscopic feature has been heightened for their tough, day-to-day challenges, so it doesn't matter if it's thrown into the back of a news truck every day or burrowed into the mud. We understand that our users work on a range of projects with different equipment, so this upgrade is meant to acclimate to light and heavy rigs without compromising the integrity and quality of the gear.” says Tobias Keuthen, Sachtler's senior product marketing manager.

Thanks to the excellent drag mechanism, the innovative Speedbalance technology for swift weight compensation, and now the larger load range, the Video 18 S2 is not only comfortable to use, but still highly reliable.

Sachtler Video 18 S2 Press Release

[PDF](#)



Collateral

Downloads (via **INTouch**, log-in required)

sachtler



VIDEO 18 S2

GREATER PAYLOAD. CHECK
SMOOTH OPERATION. CHECK
SAME GREAT PRICE. CHECK

JUST WHEN YOU THOUGHT WE COULDN'T GET ANY BETTER, WE PRESENT THE SACTHLER VIDEO 18 S2

As the only head in this class that offers fully functional smooth head operation at **-40°C to +60°C**, the Sachtler Video 18 S2 features the ability to support a full ENG Rig with up to **20 kg (44.1 lbs)** while offering a super smooth drag performance.

WHY CHOOSE THE VIDEO 18 S2

For decades, the sturdy fluid head Video 18 has had a place in the equipment list of successful EFP and EB cameramen. Thanks to the excellent drag mechanism, the innovative Speedbalance technology for swift weight compensation and the large payload range, this best-seller is not only comfortable to use, but above all, highly reliable. It comes with typical Sachtler features like temperature resistance, Touch & Go plate, parking position for spare camera screws and illuminated spirit level.

Your Video 18 S2 will help you capture the perfect shot in any circumstance. With a set up that takes seconds to erect and adjust, your Video 18 S2 supports your camera and accessories in the perfect position, and for however long you wish, so you can take images that will be shared and remembered.

THE SACTHLER 18 S2 FLUID HEAD - SUPER SMOOTH PERFORMANCE FOR AN EVEN GREATER PAYLOAD AT THE SAME GREAT PRICE



Step 1
Step 16



SEE HOW OUR CUSTOMERS USE THE HEAD



VIDEO18S2.SACTHLER.COM

Sachtler
A Vitec Group brand

SACTHLER.COM

Sachtler Video 18 S2 Sales Sheet

[PDF](#)

Advertisements

Downloads (via **INTouch**, log-in required)

sachtler 

VIDEO 18 **S2**

GREATER PAYLOAD. CHECK
SMOOTH OPERATION. CHECK
SAME GREAT PRICE. CHECK

THE ENG STANDARD - WORLDWIDE
Perfect Motion for an even greater payload at the same great price

- Fully functional in extreme temperatures.
- Able to support a full Size ENG rig with up to 20 kg (45 lbs.).
- Smooth operation.

LEARN MORE



Sachtler Video 18 S2 print ad 7"x9.75"

[PDF](#) [Print-PDF](#)

sachtler 

Greater Payload. Smooth Operation. Same great PRICE.

VIDEO 18 **S2**

Sachtler Video 18 S2 banner ad 300x250

[JPG](#)

sachtler 

GREATER PAYLOAD. SMOOTH OPERATION. **SAME GREAT PRICE.**

VIDEO 18 **S2**

Sachtler Video 18 S2 banner ad 728x90

[JPG](#)

sachtler 

GREATER PAYLOAD. SMOOTH OPERATION. **SAME GREAT PRICE.**

VIDEO 18 **S2**

Sachtler Video 18 S2 banner ad 468x60

[JPG](#)

Image Stock

Downloads (via INtouch, log-in required)



Sachtler Video 18 S2

[↓ JPEG](#)



Sachtler Video 18 S2

[↓ JPEG](#)

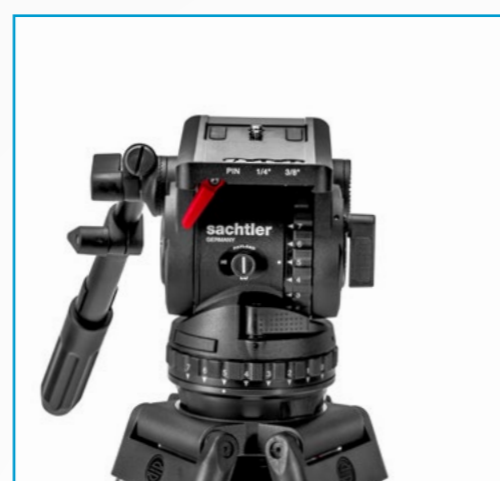

Sachtler Video 18 S2

[↓ JPEG](#)

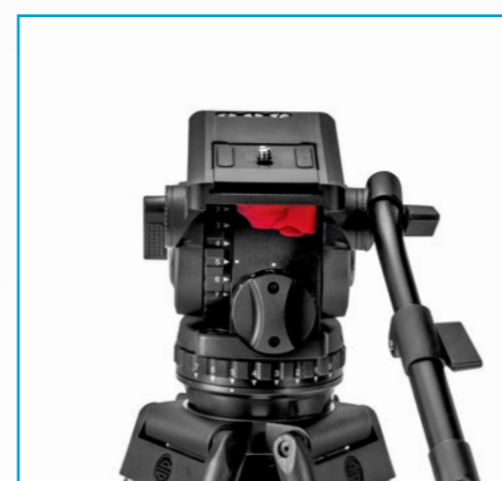

Sachtler Video 18 S2

[↓ JPEG](#)



Sachtler Video 18 S2

[↓ JPEG](#)



Sachtler Video 18 S2

[↓ JPEG](#)



Sachtler Video 18 S2

[↓ JPEG](#)

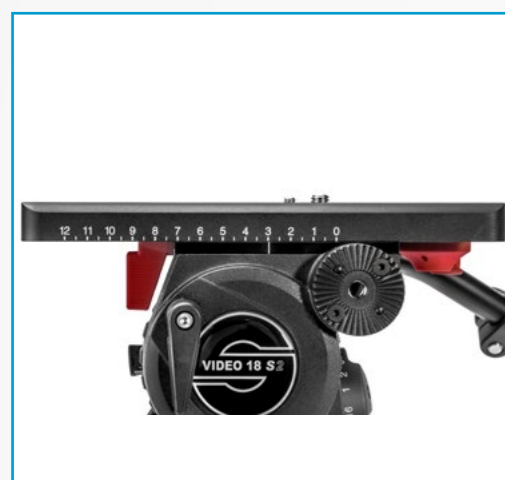

Sachtler Video 18 S2

[↓ JPEG](#)



Sachtler Video 18 S2

[↓ JPEG](#)



Sachtler Video 18 S2

[↓ JPEG](#)



Sachtler Video 18 S2

[↓ JPEG](#)



Sachtler Video 18 S2

[↓ JPEG](#)

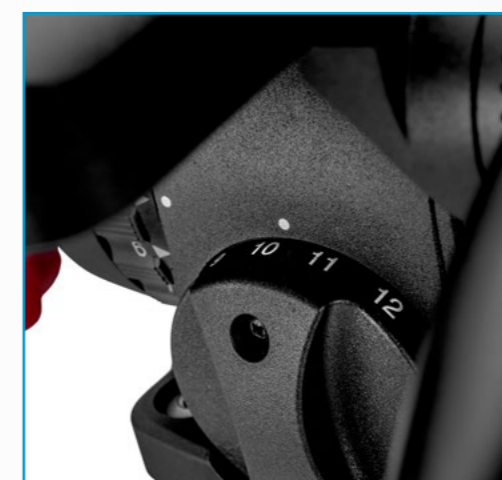

Sachtler Video 18 S2

[↓ JPEG](#)



Sachtler Video 18 S2

[↓ JPEG](#)



Sachtler Video 18 S2

[↓ JPEG](#)

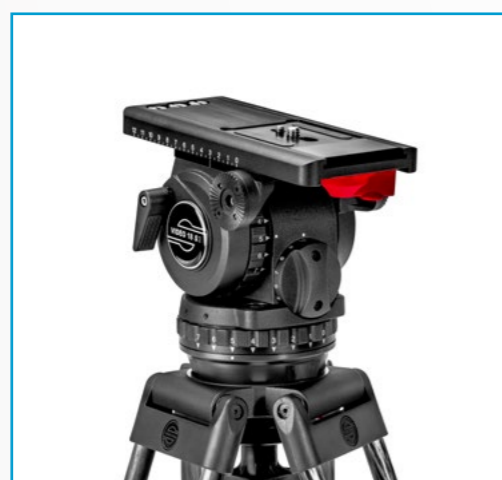

Sachtler Video 18 S2

[↓ JPEG](#)



Sachtler Video 18 S2

[↓ JPEG](#)



Sachtler Video 18 S2 + ENG 2 CF

[↓ JPEG](#)



Sachtler Video 18 S2 + ENG 2 MCF

[↓ JPEG](#)



Sachtler Video 18 S2 + SpeedLock MCF

[↓ JPEG](#)

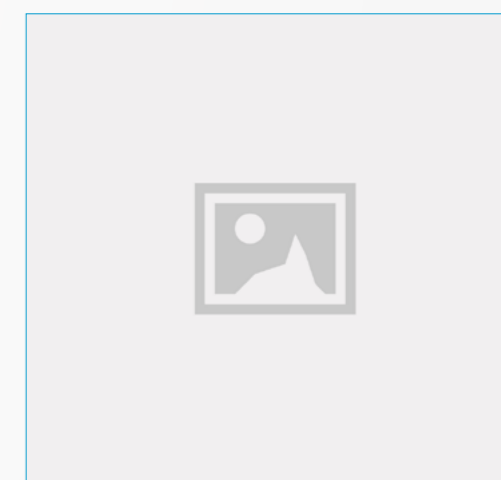

All Images (inkl. transparent .png files)

[↓ Download](#)

Testimonials

Downloads (via **INtouch**, log-in required)



Sachtler Video 18 S2 - Testimonial Video

[MP4](#)

Clinton Harn

Cinematographer who shot for two-time Academy Award winner and director Malcolm Clark

This new head just has more control, so while it can accommodate a heavier payload of 20 kg, you can still go down to the minimum drag setting of 2 kg and put a small DSLR camera on there with no issues. And that's the big difference between Sachtler and a lot of other competitors.



Sachtler Video 18 S2 - Testimonial Video

[coming soon](#)

Bertie Gregory

National Geographic wildlife filmmaker

I've taken it in little boats, big boats, I've put it in salt water to get water level shots, had it in rivers, and carried it 20 kilometers in a day. I take it onto beaches, full of sand. I've had tripods in the past where you take it on a beach, and it's windy, and the whole thing just fills up with sand, and you have to take it apart to clean it. I don't know what Sachtler's done, but whatever they've done it's genius because it doesn't get filled up with sand.

Videos

Downloads (via **INTouch**, log-in required)



Sachtler Video 18 S2 - Clinton Harn - Dessert

[MP4](#)



Sachtler Video 18 S2 Commercial - 66sec.

[MP4 - Horizontal version](#)

[MP4 - Vertical Version](#)

Website

www.video18s2.sachtler.com

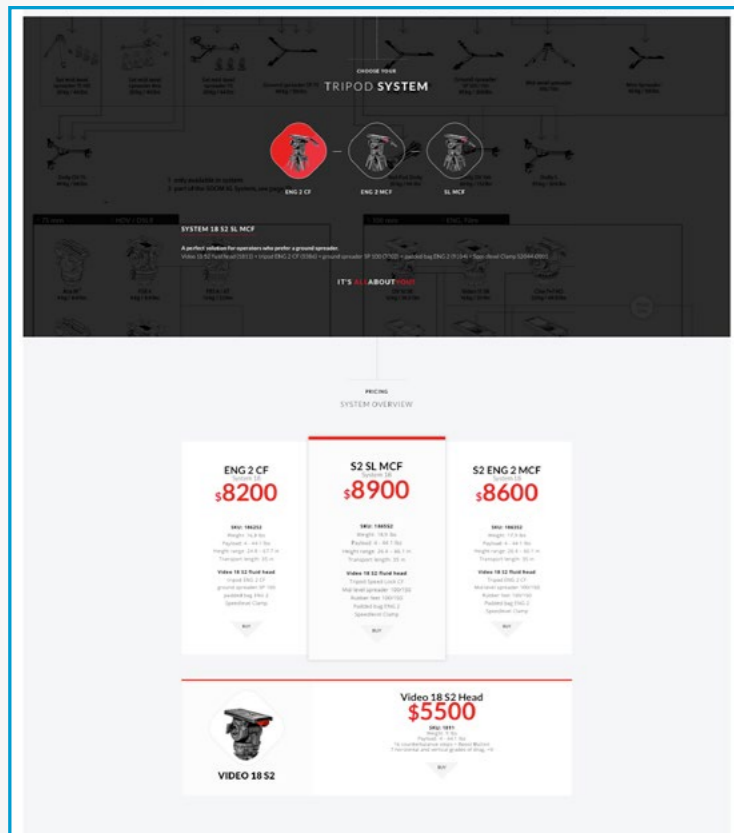
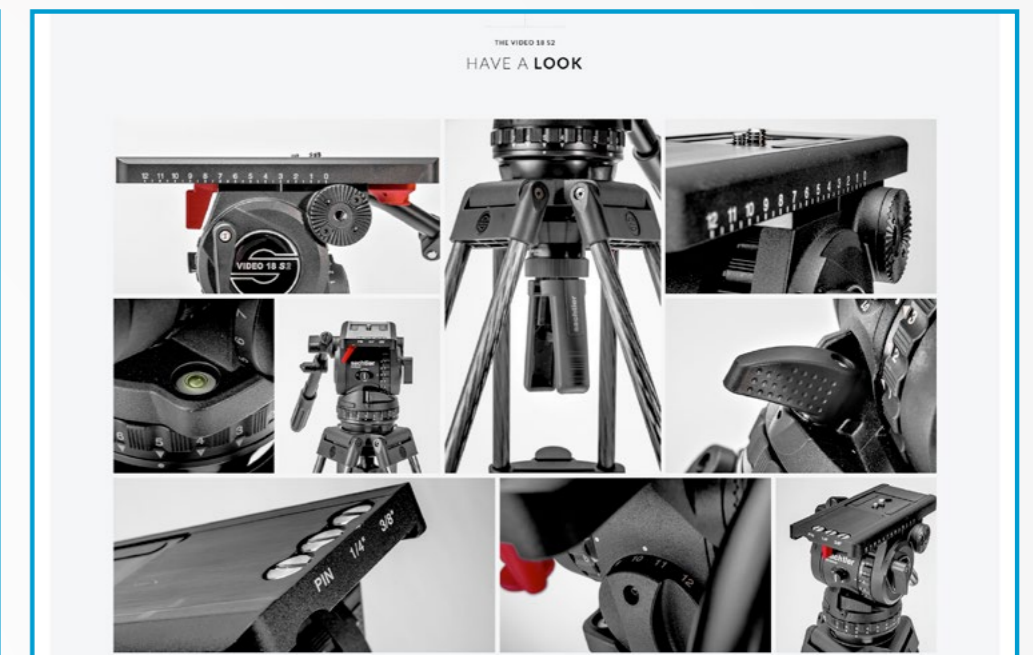
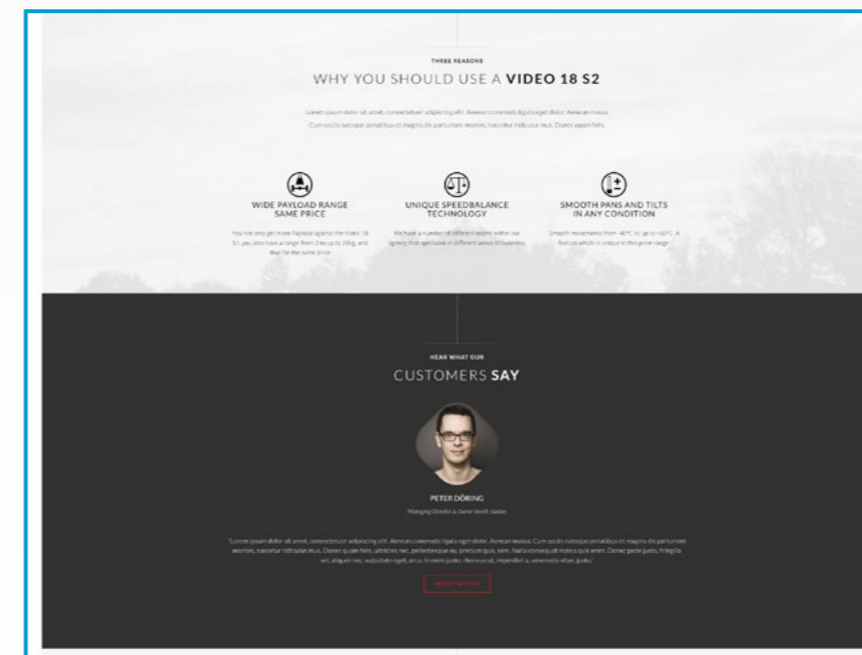
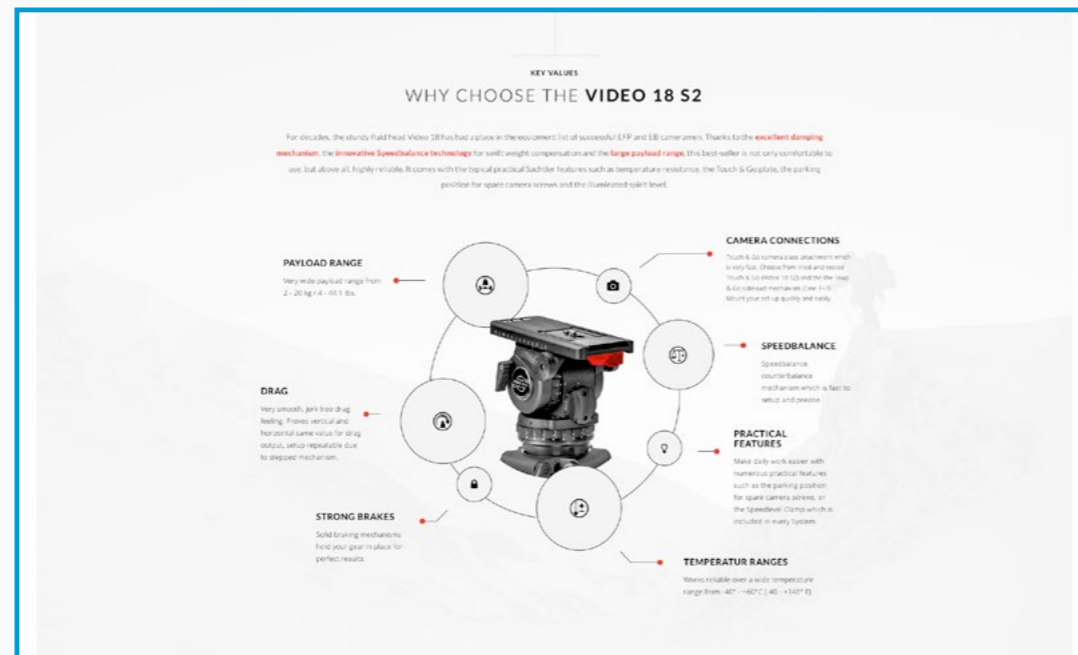
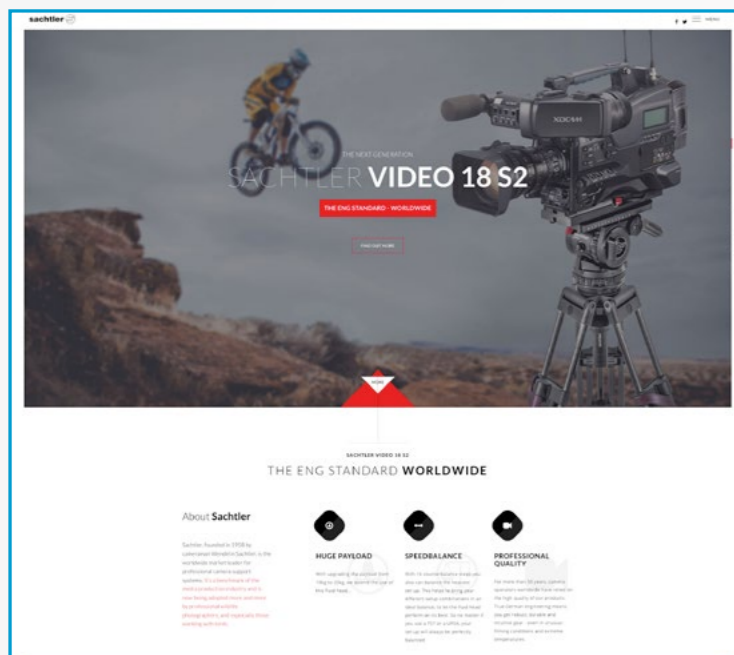

Sachtler Video 18 Microsite

[Visit](#)

Key Milestones

Order Demo kits now.

April 11

Partner Announcement

April 12

Press release issued; product pages go live

April 13

Accepting partners orders

NAB 2016

April 18

Launch at NAB; products available in Vitec Videocom warehouse

April 19

Partners start to list product.

May 1

Start of Sachtler end user campaign

Contacts

North & South America

Channel Sales:

Northeast / Mid Atlantic USA:

- ▶ Jay Ignaszewski
jay.ignaszewski@vitecgroup.com

South Central USA:

- ▶ Ken Horne
ken.horne@vitecgroup.com

Canada:

- ▶ Sol Comerchero
sol.comerchero@vitecgroup.com

West USA:

- ▶ Curtis Harris
curtis.harris@vitecgroup.com

Latin America / Brazil:

- ▶ Marco Brea
marco.brea@vitecgroup.com

VP Channel Sales USA:

- ▶ Eduardo Silva
eduardo.silva@vitecgroup.com

Partner Programs:

- ▶ Jürgen Sommer
juergen.sommer@vitecgroup.com

Channel Marketing USA:

- ▶ Tony Cacciarelli
tony.cacciarelli@vitecgroup.com

Europe & Middle East

Channel Sales:

UK / Scandinavia / S. Africa / Baltics:

- ▶ Jed Wallace
jed.wallace@vitecgroup.com

France:

- ▶ Yann Le Chanony
yann.chanony@vitecgroup.com

Germany / Austria / Switzerland:

- ▶ Martin Leuenberg
martin.leuenberg@vitecgroup.com

Russia / CIS:

- ▶ Anton Antipyev
anton.antipyev@vitecgroup.com

Mediterranean Region / Africa / Belgium / Israel / Czech Rep. / East Europe:

- ▶ Aldo di Caterino
aldo.dicaterino@vitecgroup.com

Middle East:

- ▶ Pavan Mulanni
pavan.mulanni@vitecgroup.com

Partner Programs:

- ▶ Jürgen Sommer
juergen.sommer@vitecgroup.com

Channel Marketing EMEA:

- ▶ Ruth Paskins Gordon
ruth.paskinsgordon@VitecGroup.com

Asia & Pacific

Channel Sales:

China / Hong Kong / Macau – Chief Representative:

- ▶ Jerry Du
jerry.du@vitecgroup.com

China / Hong Kong / Macau:

- ▶ Greg Min
greg.min@vitecgroup.com

Australia / New Zealand / S. Korea / Taiwan / Malaysia / Vietnam:

- ▶ Derrick Ng
derrick.ng@vitecgroup.com

Singapore / Brunei / Indonesia / Thailand / Philippines / Cambodia / Myanmar:

- ▶ Kevin Hee
kevin.hee@vitecgroup.com

India:

- ▶ Deepak Braganza
deepak.braganza@vitecgroup.com

Japan Managing Director:

- ▶ Takashi (Tad) Hino
tad.hino@vitecgroup.com

Partner Programs:

- ▶ Jürgen Sommer
juergen.sommer@vitecgroup.com

Channel Marketing Asia Pacific:

- ▶ Audrey Chang
audrey.chang@VitecGroup.com