

# Stereo VideoMic Pro

## ON-CAMERA STEREO MICROPHONE

- Broadcast recording quality on-camera microphone
- Matched pair 1/2" condenser capsules in XY stereo configuration
- Ultra lightweight, compact form factor
- Two step High Pass Filter (flat, 75Hz)
- Three position level control (-10dB, 0, +20dB)
- 9V battery powered - over 100 hours use (alkaline)
- Integrated shock mounting
- Integrated foam windscreen
- 3.5mm stereo mini-jack output
- Billeted metal camera shoe mount with 3/8" thread for easy boompole mounting
- Designed and manufactured in Australia
- Free 10 year extended warranty when you register online at [www.rodemic.com/warranty](http://www.rodemic.com/warranty)



10 YEAR WARRANTY



OVER 100 HOURS BATTERY LIFE\*



+20dB LEVEL BOOST



INTEGRATED RYCOTE® LYRE® SHOCK MOUNT



### ACOUSTIC & ELECTRICAL SPECIFICATIONS

Acoustic Principle:	Pressure gradient
Directional Pattern:	XY Cardioid (coincident)
Frequency Range:	40Hz ~ 20,000Hz (selectable HPF@75Hz)
Sensitivity:	-38dB (12.6mV@94dB SPL) ±2dB re 1V/Pa @ 1kHz
Output Impedance:	200Ω
Equivalent Noise:	20dBA SPL (A - weighted per IEC651)
Maximum Output:	+4.2dBu (@ 1% THD into 1kΩ)
Dynamic Range:	100dB (per IEC651)
Max SPL:	134dB (@ 1kHz, 1% THD into 1kΩ load)
Signal/Noise:	73dB SPL (A - weighted per IEC651)
Power Requirements:	9V alkaline battery



## MECHANICAL SPECIFICATIONS

Weight (grams):	115g (0.25lb)
Dimensions (millimetres):	Length: 107.8
	Width: 65.3
	Height: 129.9
Output Connection	3.5mm stereo mini-jack

## WHATS IN THE BOX



Stereo VideoMic Pro

## DIMENSIONS

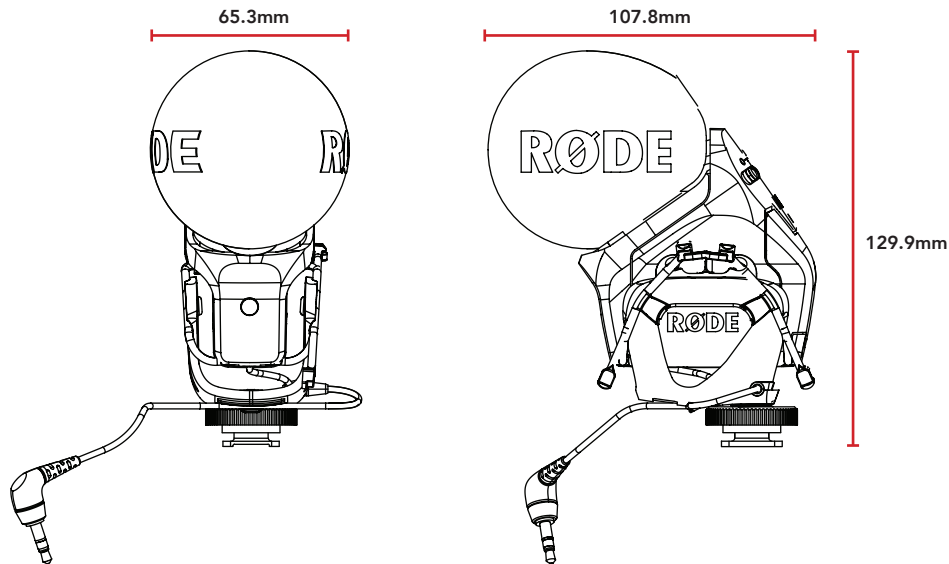

## POLAR PATTERN

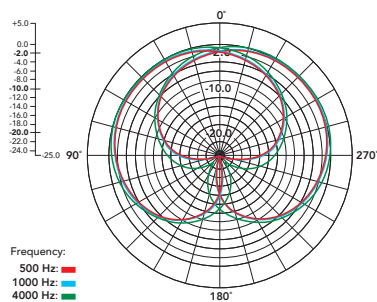

## FREQUENCY RESPONSE

